



www.vdo.com

# Modular Tachograph

## MTCO 1324

The MTCO 1324 modular EC tachograph sets new standards in performance, technology and design thanks to its separate display and recording elements.

Speed and distance travelled, as well as driver-related data such as driving, working and rest times, are recorded on conventional, tamperproof paper charts. The driver and co-driver can conveniently select the relevant working time group via the operating keys. The date, time, distance, events and service and diagnostics data can be called up on the LCD display. Speed is indicated via the E-Tacho 1323 electronic speedometer or via an approved display function integrated into the instrument cluster. To use the MTCO 1324, a KITAS 2171 speed sensor is required – this delivers encrypted, tamperproof pulses for capturing speed and distance. Fully compliant with Regulation (EEC) No. 3821/85, the radio slot-sized MTCO 1324 is an innovative system component which can be easily integrated into advanced cockpit concepts.

### Features

- Automatic warnings
- Multifunctional LCD display with 2 x 16 characters
- Recording unit for ISO 7736 radio-sized slot
- Flipdown or fixed drawer design
- Drawer for two charts, locked and unlocked via ignition key
- Battery-buffered real-time clock with automatic changeover to summertime
- Automatic positioning of recording chart to match the time of day
- Automatic change of time groups and cut-off of distance recording after 25 hrs

### Options

- Customer-specific front panels
- CAN interface
- Stand-alone version with digital speed indication
- Info interface

**VDO**

# Modular Tachograph

MTCO 1324 (standard version)

## Technical Information

Measuring range	125 km/h
Operating temperature	-25 ... +70°C
Operating voltage	24 V
Pulse range	2,400 to 25,000 pulses/km
Inputs / outputs	v-sensor, v-pulse, programming and instrument interface, 4 pulses/m
Accuracy	Speed $\pm 3$ km/h, distance $\pm 1\%$ , time $\pm 5$ sec/day
EMC	RL 95 / 94 / EC ISO 7637
Housing	Steel, galvanised
Weight	~ 1,350 g
Additional special options	GGVS (German Dangerous Goods Ordinance Road), 12 volts, 3300 rpm, CAN interface for instrument and vehicle, diagnostics interface via CAN (diagnostics/CAN interface based on ISO 16844), illuminated operating keys, dimmable display, measuring ranges 100/140/180 km/h, additional recording, info interface, stand-alone version with digital speed indication
Mounting frame	A mounting frame conforming to ISO 7736 is required for installation

Dimensions for installation (in mm):

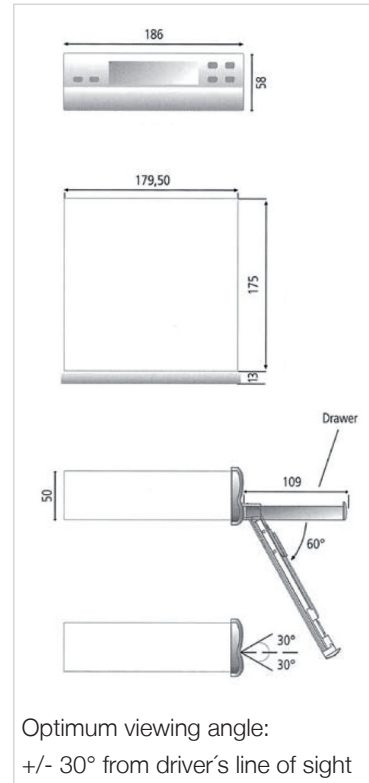

## Functional overview

Function	MTCO displays	Recording chart	Display via E-Tacho 1323	Data via optional CAN interface
Road speed	° 3)	•	•	•
Date	•	1)	-	•
Time	•	2)	°	•
Odometer	•	1)	•	•
Trip odometer	-	2)	°	•
Driving, working and rest times	•	-	-	•
Events/faults	•	•	•	•
Additional stylus	-	°	-	-
Engine speed	-	°	-	•

• Standard    ° option    - not planned    1) manual    2) graphical    3) excluding date display